

# Rebuild Instructions

## P45AC6 Air Compensated Pintle Hook

Use with replacement part kits: C6200, C6300, & C6400

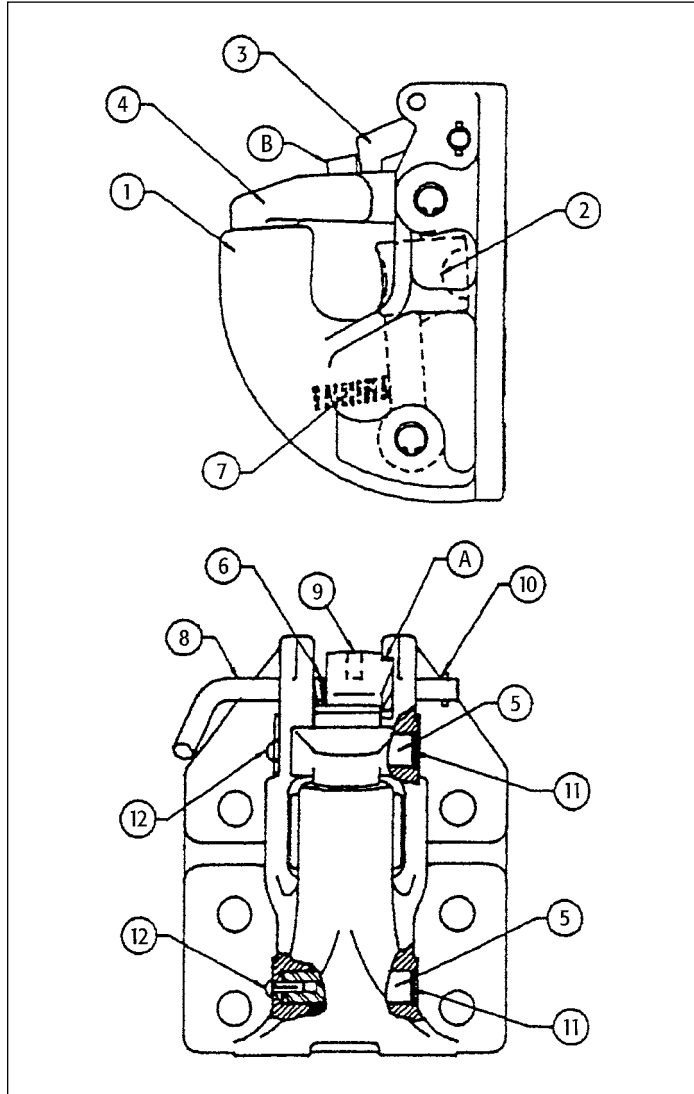

### INSPECTION

#### A. Body Inspection

1. Visually inspect the pintle hook Body Casting (1) for signs of excessive wear, or fatigue such as deformation or cracks. If any such conditions are noted, the entire hook should be replaced. (This is a good time to check the mounting structure, bolts, and air chamber. Contact vehicle manufacturer for guidelines.)



ITEM NO.	PART NO.	DESCRIPTION	C6200	C6300	C6400
1	-	Body Casting	-	-	-
2	C4002	Plunger Arm	1	-	1
3	C6003	Lock	-	1	1
4	C6004	Jaw	1	-	1
5	C6005	Shaft	2	-	2
6	C6006	Torsion Spring	1	1	1
7	C6007	Compression Spring	1	-	1
8	C6008	Actuator	-	-	1
9	C6009	Set Screw	-	1	1
10	C6010	Roll Pin	1	1	1
11	C6011	Retaining (Snap) Ring	2	-	2
12	C6012	Grooved Pin (Rivet)	2	-	2

#### B. Pivot Shaft Inspections

1. Verify that the Shafts (5), Snap Rings (11), and Grooved Pin Rivets (12) are in place and secure. See Fig. 1 on pg. 2 for proper location of Snap Rings.

#### C. Jaw Inspection

1. Place a properly matched lunette eye on the hook, lower the Jaw (4) and apply operating pressure to the air chamber.  
 2. With the Lock disengaged, as shown in Fig. 2 on pg. 2, lift the Jaw (4) until it stops. The secondary interlock feature must prevent the Jaw from opening more that 1/2" above the horn.

-continued



Correct

A properly installed snap ring will be open when seated.

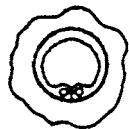

Wrong

The snap ring is closed indicating it is out of position.

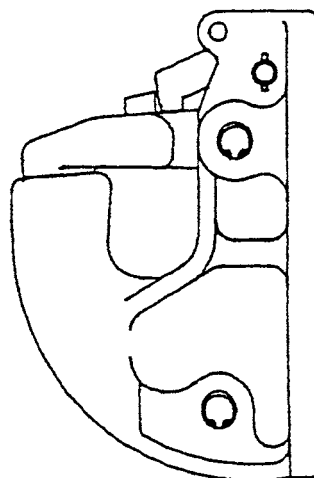

Fig. 1

3. If the space exceeds 1/2", replace the Jaw and Plunger Arm using replacement Jaw Kit C6200 of the Rebuild Kit C6400.

**D. Lock Inspection**

1. Grasp the Lock Actuator (8) and without compressing the Spring (6) rotate the Actuator handle to lift the Lock (3) until it stops against the Body undercut (A). The "tooth" of the Lock must not clear the stop (B) on top of the Jaw (4). If the lock clears the stop (B) as shown in Fig.3:

- a. Inspect the undercut (A) on the Body, if the undercut is not clean and square the entire hook should be replaced.
- b. If the under cut is in good condition, then install a new Lock Kit C6300 or Rebuild Kit C6400.

**E. Full Rebuild**

If inspection steps A-D indicate that both the Lock and Jaw mechanisms require replacement, then the Rebuild Kit C6400 should be used.

**JAW KIT C6200**

In order to perform this repair, it will be necessary to remove the hook from the vehicle.

**A. Disassembly**

1. Remove the Roll Pin (10) from the Actuator (8), loosen the Set Screw (9) and pull the Actuator (8) out of the assembly. This will release the Lock (3) and the Torsion Spring (6) from the assembly.

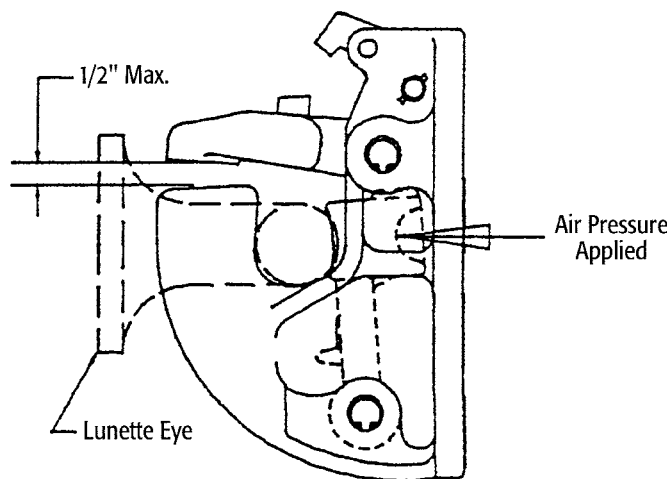

Fig. 2

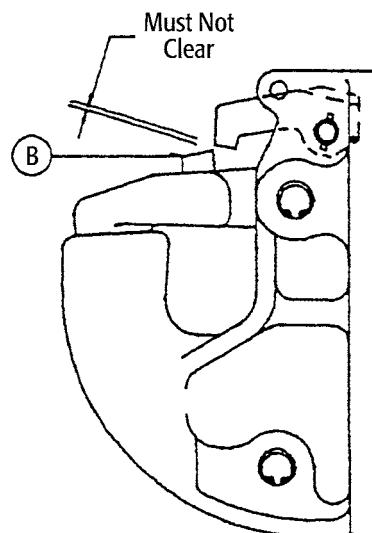

Fig. 3

2. Remove the Shafts (5) that secure the Jaw (4) and Plunger Arm (2) by removing the head of the Rivets (12) using a cold chisel or by grinding (eye protection is required.) Then remove the Retaining Rings (11) with the proper snap ring tool. Complete the disassembly by inserting a pin through the rivet holes in the Body and driving out the old Shafts.

3. Clean and inspect the Body for any damage, which may not have been detected during initial inspection.

4. Clean the snap ring grooves and verify that they have not been crushed or broken through. If the snap ring grooves are damaged the entire hook must be replaced.

### B. Plunger Arm Installation

1. Apply a liberal amount of a good grease inside the shaft hole in the new Plunger Arm (2). Holding the new Plunger Arm in the position *illustrated by Fig. 4*, insert it through the opening in the back (mounting face) of the Body until it stops against the horn of the hook.

2. Rotate the Plunger Arm 90° to allow the pivot end to move down into position to align with the lower holes in the Body.

3. Insert new Compression Spring (7) into the recess in the Body and onto the post on the Plunger Arm, and insert the new Shaft (5). The end of the Shaft that has a hole for the Rivet is inserted first. Do not install the new Snap Ring or Rivet at this time.

### C. Jaw Kit Installation

1. Apply a liberal amount of a good grease inside the shaft hole in the Jaw (4). Place the Jaw into position in the Body and insert the new Shaft (5). Do not install the Snap Ring at this time.

2. Place a lunette eye of the proper size onto the hook. With the Jaw resting on the top of the horn, verify that the Air Chamber will be able to push the Plunger Arm against the eye.

3. If interference of the Jaw and Plunger Arm will not allow the Plunger to contact the eye, remove

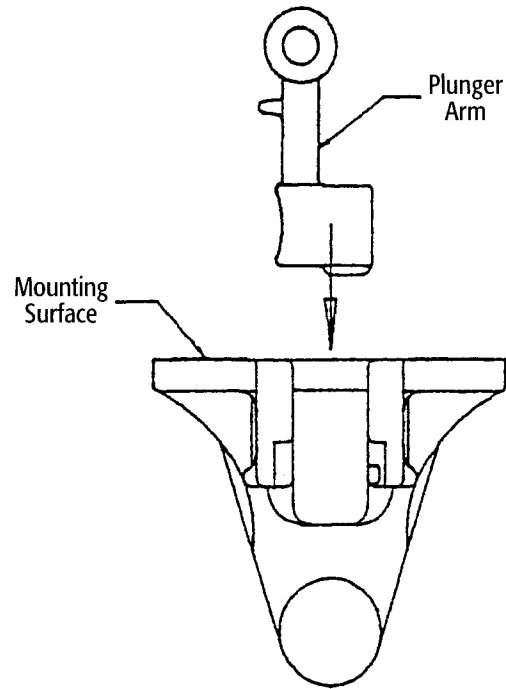

Fig. 4

the Jaw and inspect for any burrs and carefully file or grind to allow free movement. Care should be taken not to remove an excessive amount of material. Reinstall the Jaw and repeat step 2.

4. With the lunette eye in place and the Plunger held against the eye, verify that the Jaw will not lift more than 1/2" above the horn as in inspection step C2.

### D. Lock Installation

1. Reassemble the Lock mechanism as described below in the Lock Kit C6300 section.

### E. Secure the Pivot Shafts

1. Install the Rivets by providing a back stop against the end of the Shafts on the snap ring side of the hook and driving the Rivets (12) into the holes provided in the end of the Shafts (eye protection required.) DO NOT USE THE SNAP RING TO BACK-UP THE RIVETING.

2. Install the Snap Rings (11) and inspect as shown in Fig.1.

-continued



## **LOCK KIT C6300**

### **A. Disassembly**

1. Remove the Roll Pin (10) from the Actuator (8), loosen the Set Screw (9) and pull the Actuator out of the assembly. This will release the Lock (3) and the Torsion Spring (6) from the assembly.

### **B. Lock Installation**

1. Install the new Torsion Spring (6) onto the Actuator so that the left end will rest on the shelf provided in Body and the right end will insert into the small hole at the back of the Lock.
2. Take note of the location of the flat area on the Actuator shaft. Insert the Actuator through the Lock and the right side hole in the Body. Tighten the Set Screw (9) against the flat area on the Actuator.
3. Install the Roll Pin (10) through the hole in the end of the Actuator.

## **FULL REBUILD KIT C6400**

The Rebuild Kit contains all parts required to rebuild the P45AC6 Pintle Hook Assembly. The rebuild procedure is to follow the instructions to:

1. Replace the Jaw and Plunger Arm per Instructions for Kit C6200; then
2. Replace the Lock per the instructions for Kit C6300.